

DR PMS 400

High-performance gearless drive system

A smooth drive

Strong benefits at a glance

- Delivers unparalleled ride quality
- Operates reliably and quietly
- Meets EU safety codes and standards
- Saves on energy consumption
- Environmentally friendly
- Quickly and flexibly installed with minimised downtimes

Reliable, quiet and high performing: DR PMS 400.



Silence and comfort with every ride.

Meet the future

After more than 20 years in operation, the repair and maintenance costs for an elevator drive increase exponentially. The European Guideline EN81-80 (SNEL, Safety Norm for Existing Lifts) sets out the strict safety requirements which will apply to both new and existing lifts. This could be costly for lift owners. Avoid these extra costs by installing a modern Schindler drive and meet tomorrow's demands, today.

Silence and comfort

The gearless machine drive operates reliably and quietly. With its high level of efficiency and its modern frequency control the DR PMS 400 cuts operating cost and offers all features you need for an unparalleled ride comfort. Its unrivalled levelling accuracy safeguards passengers from the risk of tripping when stepping into or out of the car.

Safety first!

No need for an extra rope brake or safety gear. The DR PMS 400 is designed to fully meet the demands of the SNEL safety norm for protection of existing lifts from uncontrolled movements. Its brake acts directly on the traction sheave, and the state-of-the-art double or triple brake system ensures that the brakes are applied quietly and safely.

KT
Kits

AC
Accessories

CW
Counter-weights

SA
Safeties

FI
Fixtures

CA
Cars

DO
Doors

MM
Mechanical material

CO
Controls

DR
Drives

High-performance with every ride

Whether in an office building, a shopping mall or a hotel. No matter where you operate your elevator. No matter whether you run a single lift or a group of elevators. Available in three sizes, the high-performance drive system Schindler DR PMS 400 is ideal for higher load or speed requirements. With speeds from 0.63 to 2.5 m/s and load capacities up to 2.000 kg it meets all demands of low and mid-rise residential or commercial buildings.

Ecologically sound

The compactly-designed permanent magnet motor saves on energy. It does the job without any gear oil and requires minimum maintenance efforts. A relief for the environment.

Compact, efficient and safe. Next level in technology: DR PMS 400 replaces an old drive (right in the picture).



Safety included. State-of-the-art triple brake system.

Flexibility at its best

The DR PMS 400 fits flexibly into any existing machine room. With its reduced size and variable positioning of the deviation pulley, the machine drive is quickly installed. When needed, a machine support can offer a direct floor mounting. Naturally with minimum extra costs, downtime is minimised to the relief of both operators and users.

Additional safety components

DR PMS 400 can additionally be equipped with a brake release lever as well as a manual evacuation device, stored in the machine room. Both to be used in case of a manual evacuation.

A broad application range of DR PMS 400

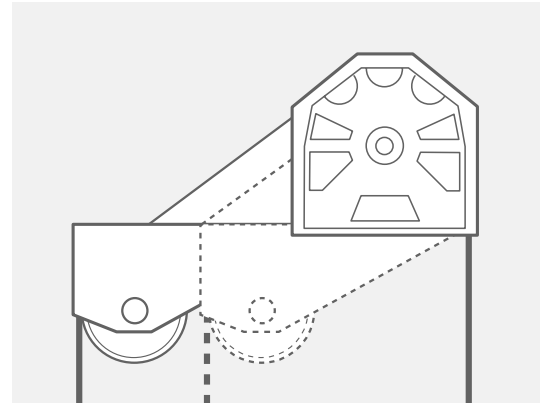
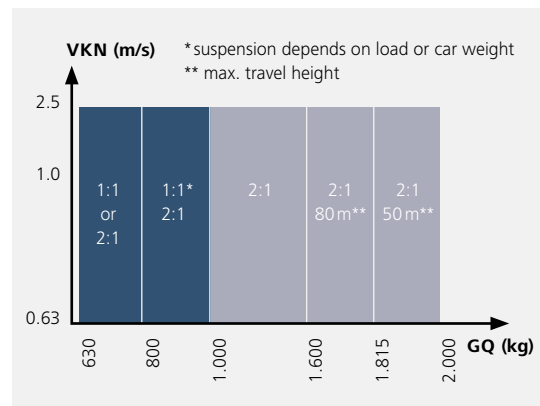

Flexible enough to fit into any existing machine room. Variable position of the deviation pulley.

Technical data

Drive	gearless technology
Brake system	disk brake on traction sheave (2 or 3 callipers)
Traction sheave diameter	410 mm
Loading capacity (GQ)	630 kg to 2.000 kg
Speed (VKN)	0.63 m/s to 2.5 m/s
Rope fall distance	450 mm to 1.600 mm
Suspension factor	1:1, 2:1
Motor	permanent magnet
Stopping accuracy	± 3mm
Starts per hour	up to 240

Schindler DR PMS 400 – upgrade the performance, comfort, safety and cost-efficiency of your lifts, ready for the future.

To suit your modernisation needs, our specialists are looking forward to advising you on the optimum solution.

Find your nearest office:

www.schindler.com